

3-1

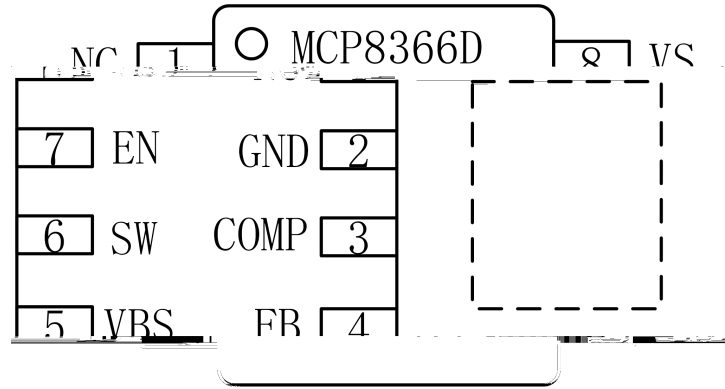

4-1

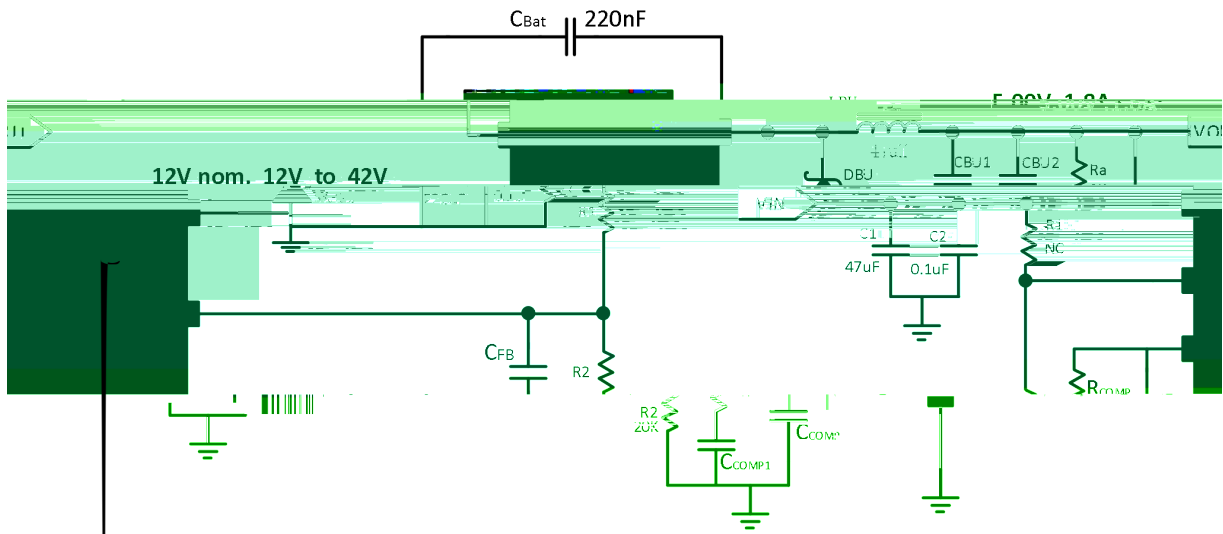



8366

300 A

2

4-2

B

2 B/ 2 --> 2 0.6 /300 A =2

1 4.1 B

4.1

B 0.5

$$T = -40 \quad +150 \quad ;$$

↓	-0.3	5.5	
		6.2	$<10^{-2}$
B	-0.3	5.5	
B	-0.3	5.5	
	-2.0	+0.3	
	-0.3	45	
	-0.3	45	
	-40	150	
	-40	150	
	-2	2	B ³
	-500	500	

2

		4.75	42		
		0.60	16		
	B	18	56		
	B 1	33	-		
	B 1	-	0.3		1
		-40	150		

1

:

1		-	10	12	/	-	
1	A ¹	-	52	-	/	2	

1)

2

76.2 114.3 1.5 52-1,-5,-7 2 2 4 B (2 70) B

,

1

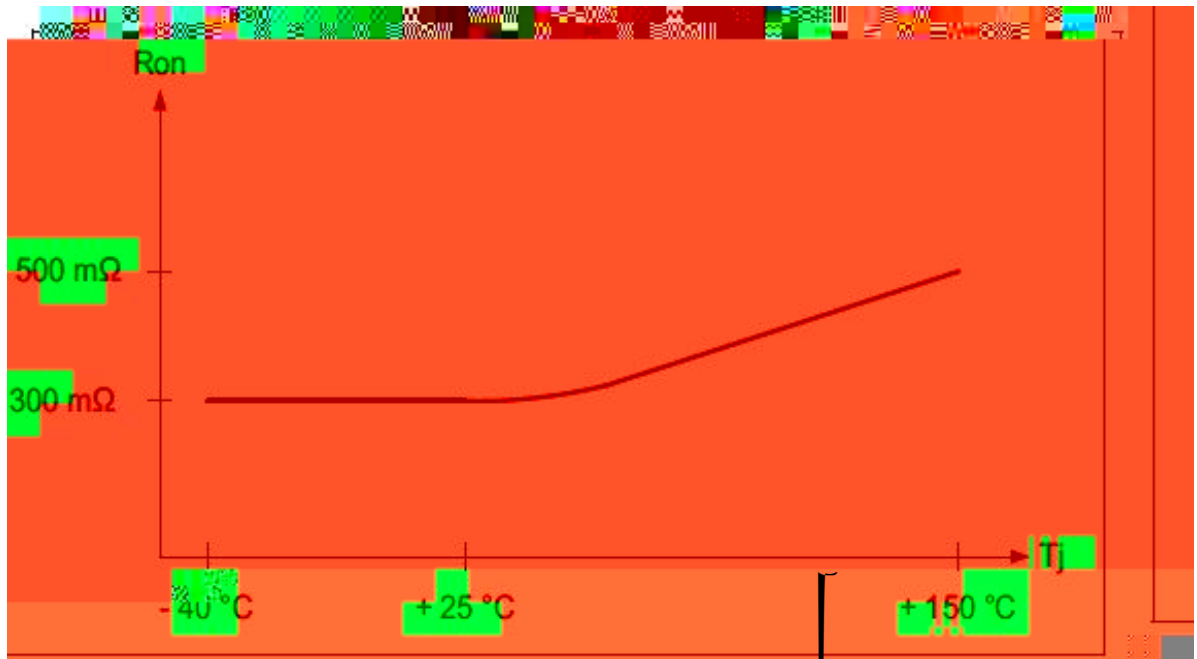

6-2

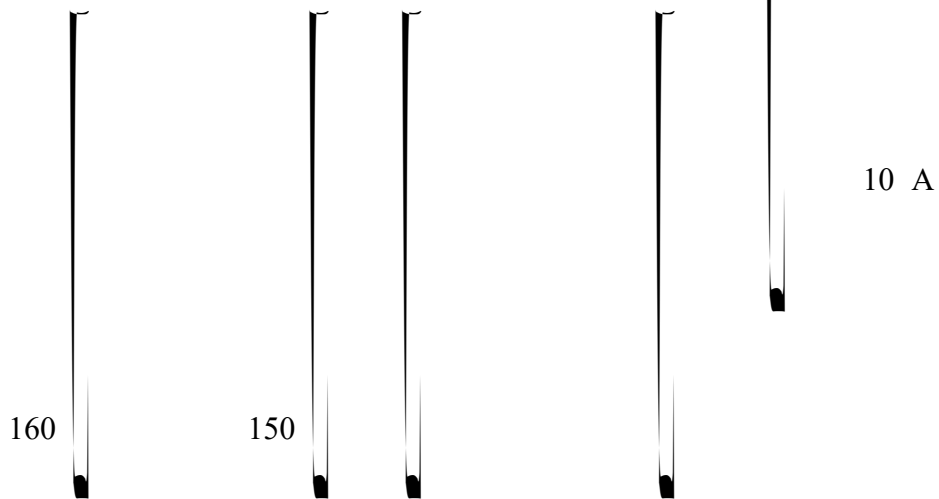

=6.0 42 , =-40 +150 ,

	<i>I</i> ,		8	10	A	=0.8 <105 =16
	<i>I</i> ,			550	A	=5 =0 A =16 B=
	<i>I</i> ,			550	A	=5 =1A =16 B=
	<i>V</i> ,	1	1.08	1.15		
	<i>V</i> ,	0.7	0.78	0.85		
	<i>V</i> ,	50	200	400		
	<i>I</i> ,			1	A	=16
	<i>I</i> ,		0.1	1	A	=0.5
	<i>T</i> ,		150			
	<i>T</i> ,		15			

1

=6.0 40 =-40 +150

	<i>f</i>	330	370	420	

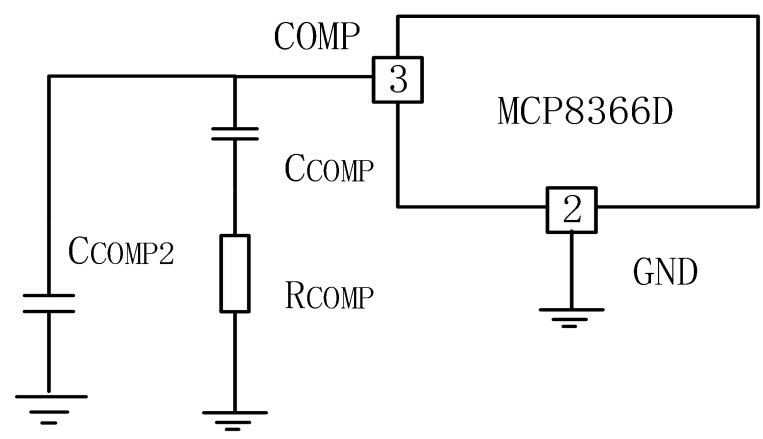
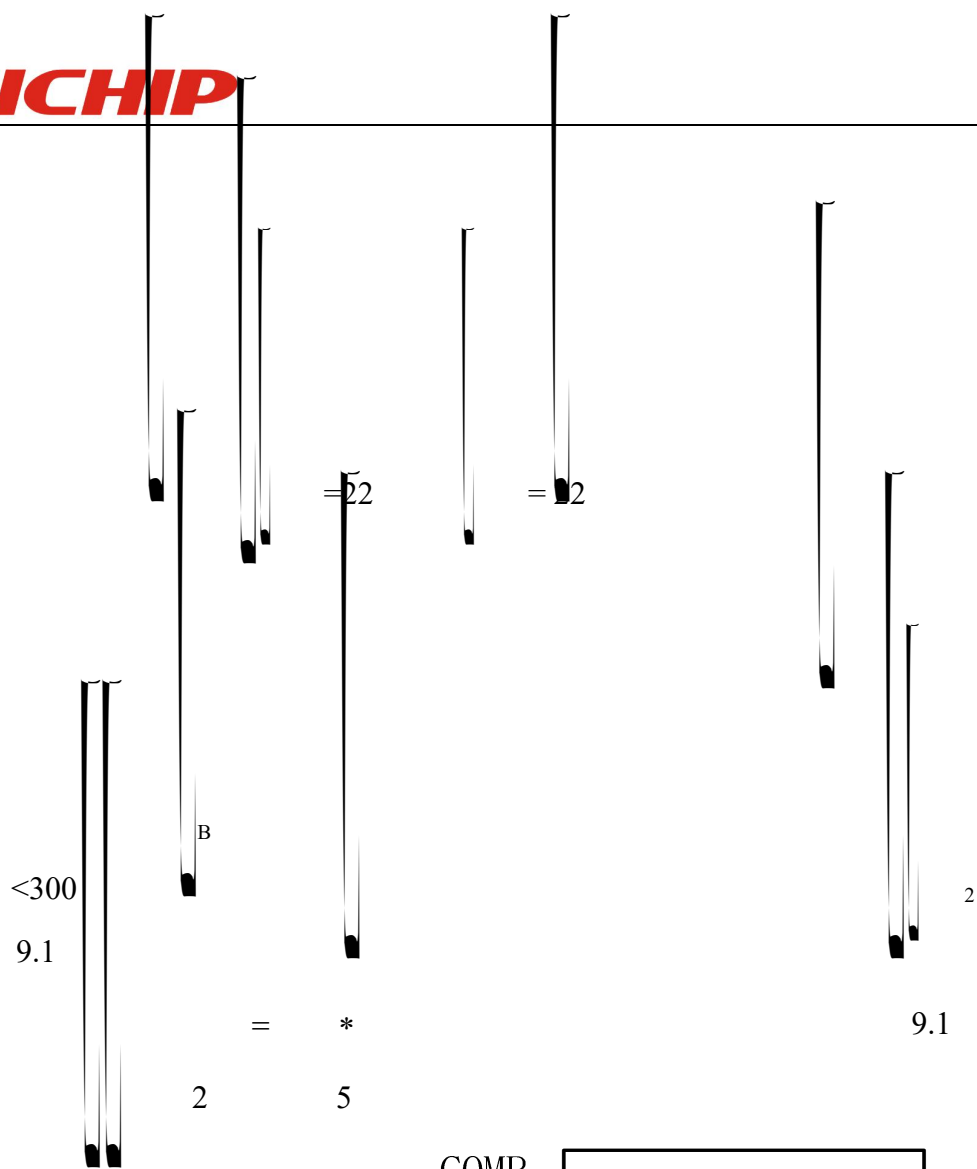

9-1

3A/60

	8366	-8		8366	2500 / &